



DC COMPONENTS CO., LTD.

DISCRETE SEMICONDUCTORS

2SC1815

TECHNICAL SPECIFICATIONS OF NPN EPITAXIAL PLANAR TRANSISTOR

Description

Designed for use in driver stage of AF amplifier general purpose amplification.

Pinning

- 1 = Emitter
- 2 = Collector
- 3 = Base

Absolute Maximum Ratings (T_A=25°C)

Characteristic	Symbol	Rating	Unit
Collector-Base Voltage	V _{CB0}	60	V
Collector-Emitter Voltage	V _{CEO}	50	V
Emitter-Base Voltage	V _{EBO}	5	V
Collector Current	I _C	150	mA
Base Current	I _B	50	mA
Total Power Dissipation	P _D	400	mW
Junction Temperature	T _J	+150	°C
Storage Temperature	T _{STG}	-55 to +150	°C

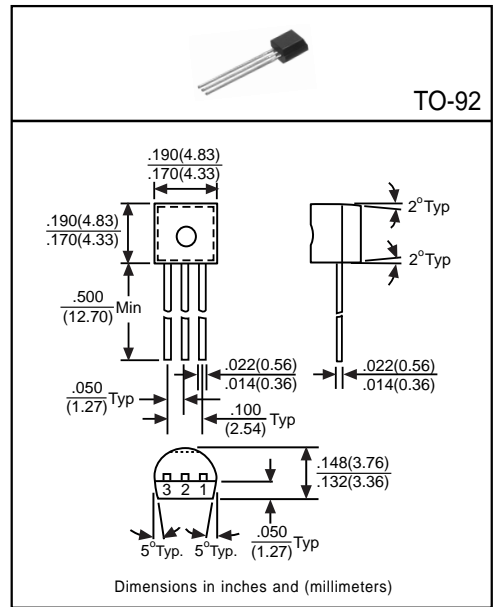

Electrical Characteristics

(Ratings at 25°C ambient temperature unless otherwise specified)

Characteristic	Symbol	Min	Typ	Max	Unit	Test Conditions
Collector-Base Breakdown Voltage	BV _{CB0}	60	-	-	V	I _C =100μA, I _E =0
Collector-Emitter Breakdown Voltage	BV _{CEO}	50	-	-	V	I _C =1mA, I _B =0
Emitter-Base Breakdown Voltage	BV _{EBO}	5	-	-	V	I _E =10μA, I _C =0
Collector Cutoff Current	I _{CBO}	-	-	100	nA	V _{CB} =60V, I _E =0
Emitter Cutoff Current	I _{EBO}	-	-	100	nA	V _{EB} =5V, I _C =0
Collector-Emitter Saturation Voltage ⁽¹⁾	V _{CE(sat)}	-	-	0.25	V	I _C =100mA, I _B =10mA
Base-Emitter Saturation Voltage ⁽¹⁾	V _{BE(sat)}	-	-	1	V	I _C =100mA, I _B =10mA
DC Current Gain ⁽¹⁾	hFE1	70	-	700	-	I _C =2mA, V _{CE} =6V
	hFE2	25	-	-	-	I _C =150mA, V _{CE} =6V
Transition Frequency	f _T	80	-	-	MHz	I _C =1mA, V _{CE} =10V
Output Capacitance	C _{ob}	-	-	3.5	pF	V _{CB} =10V, f=1MHz, I _E =0

(1) Pulse Test: Pulse Width ≤ 380μs, Duty Cycle ≤ 2%

Classification of hFE1

Rank	O	Y	GR	BL
Range	70~140	120~240	200~400	350~700